

| REV 更改号 | DATE 日期 | REVISION DETAILS 更改内容 | APPD 审核并批准 |
|------------|---------------|--------------------------|---------------|
| A | JUN. 31. 2018 | Production issue | |

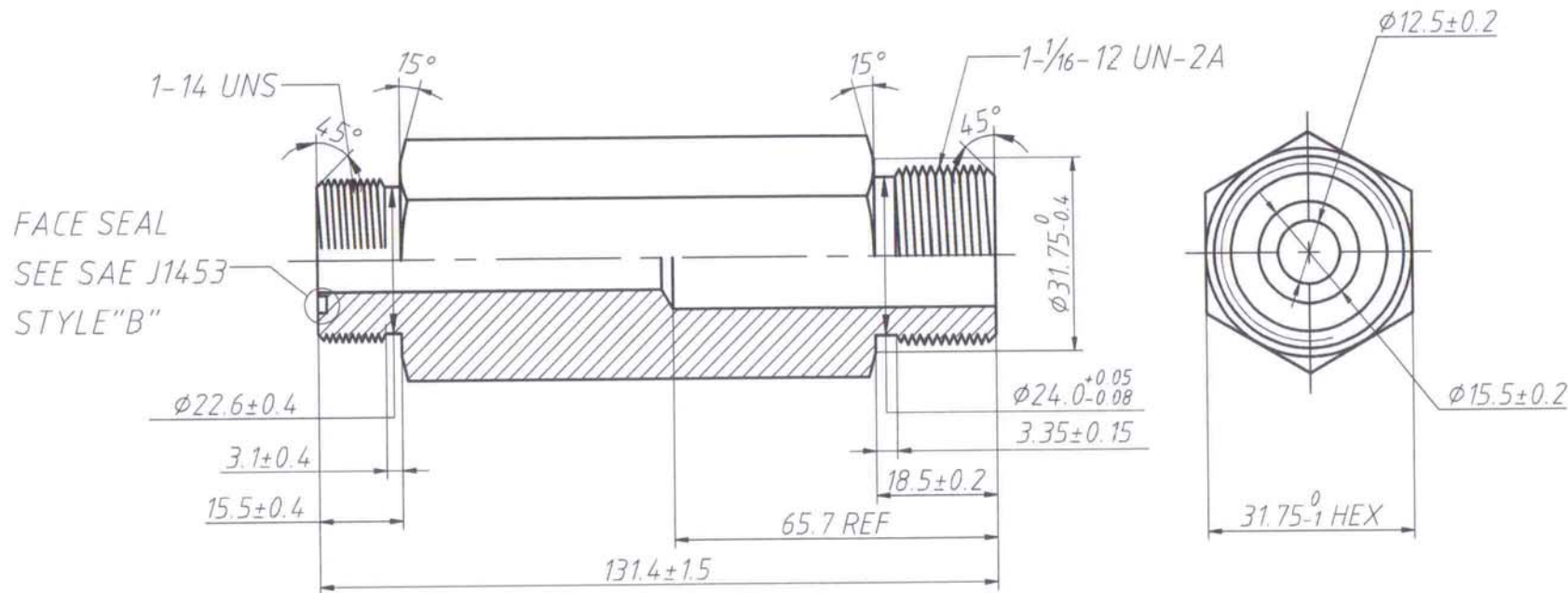

UNLESS SPECIFIED
ALL DIMENSIONS IN mm,
MACHINED SURFACES Ra=3.2um,
ANGLE TOLERANCES $\pm 5^\circ$,
Other tolerance except angles,
in accordance with
GB/T1804-2000(ISO2768-1)-m
and GB/T1184-1996(ISO2768-2)-m

其它事项,
图示尺寸单位为mm,
未注机加工表面粗糙度 Ra=3.2um,
未注角度公差 $\pm 5^\circ$,
其它未注公差 (除角度外) 均按:
GB/T1804-2000(ISO2768-1)-m 和
GB/T1184-1996(ISO2768-2)-m

MATERIAL Chinese steel 45

FINISH Remove all sharp edges,burrs,silvers and swarf, break all edges 0.127-0.254mm.
ZINC PLATING WITH 8um MICRONS MINIMUM PLATING THICKNESS AND TRIVALENT CHROMATE PASSIVATION
AND WITHSTAND 96 HRS TO WHITE / 144 HS TO RED RUST IN SALT SPRAY TEST.

去除所有毛刺, 铁屑等残留物, 锐边倒钝0.127-0.254mm.
镀锌, 三价铬钝化, 银白色, 盐雾试验96小时无白斑, 144小时无红锈, 镀锌层厚度大于8um.

| Zhejiang Gaocheng Autoparts Co.,Ltd | | |
|-------------------------------------|--------------------------|------------|
| PART No 零件名 | 41317-10FS-12 | |
| SCALE: | APPD: 批准 Zhang | DRN: 制图 |
| NTS | DATE: 日期 2018. 07. 31 | CHK: 审核 |